

Networks for reversible logic

Alexis De Vos and Yvan Van Rentergem
Universiteit Gent
Belgium

Freiberg, 18 September 2008

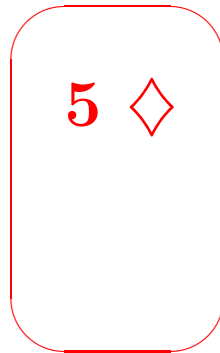

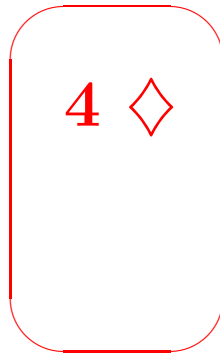
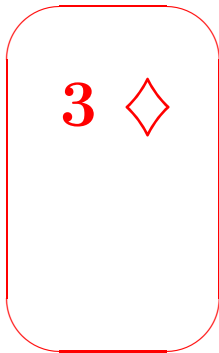
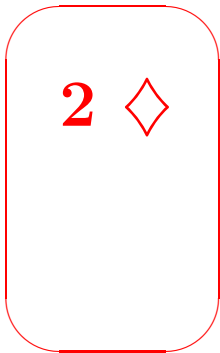
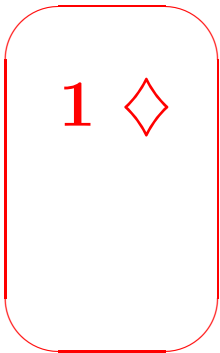
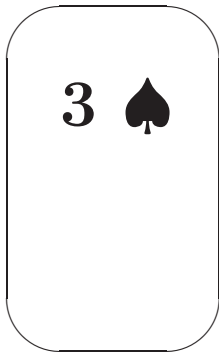
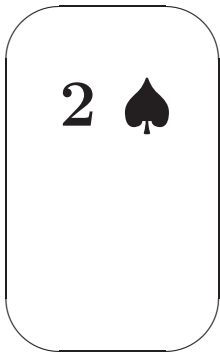
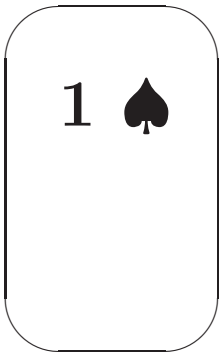
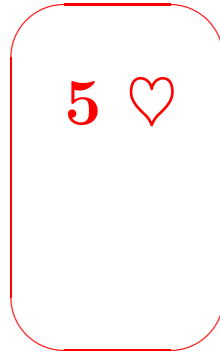
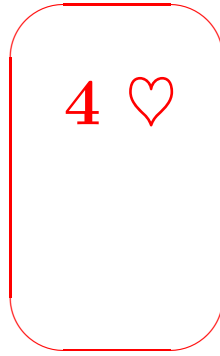
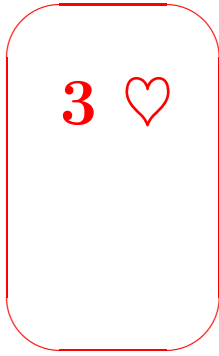
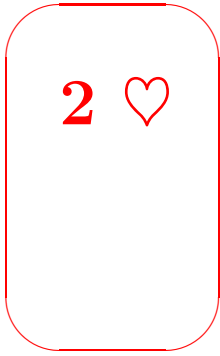
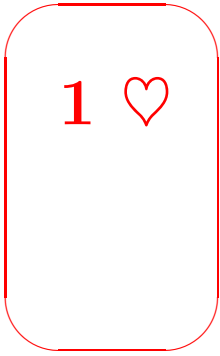

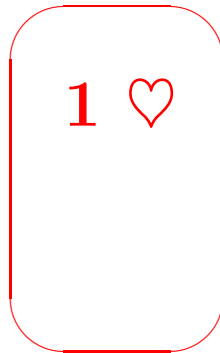
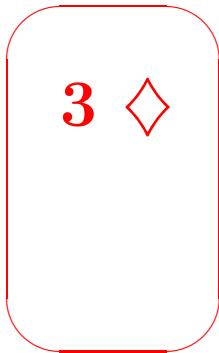
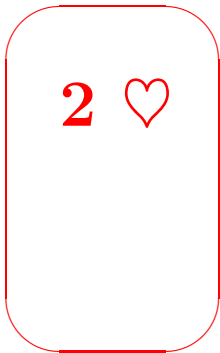
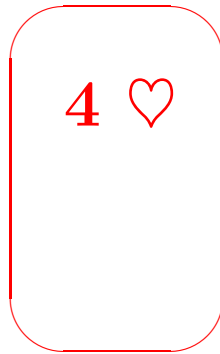
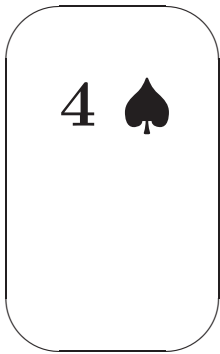
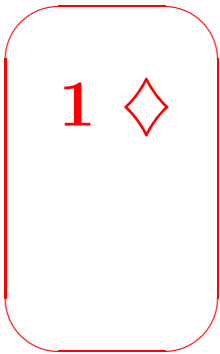
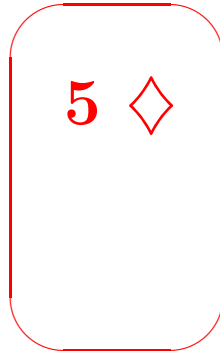
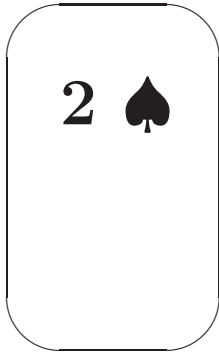
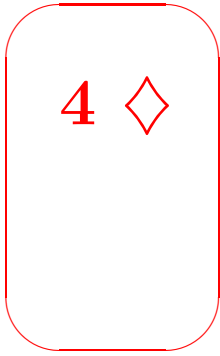
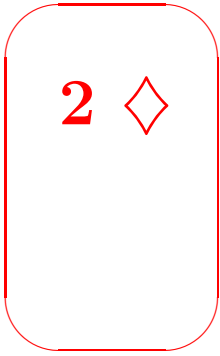

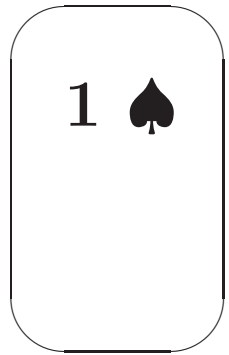
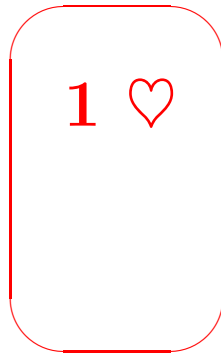
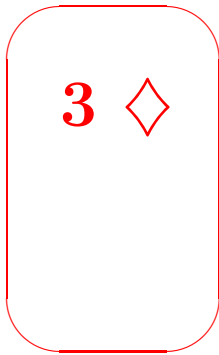
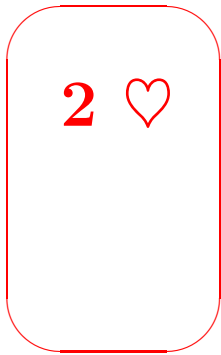
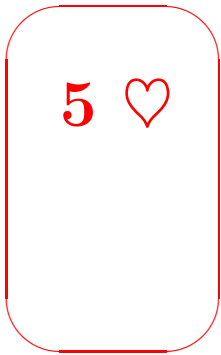
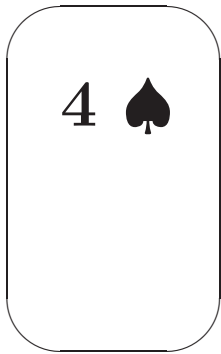
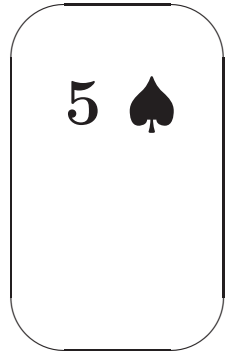
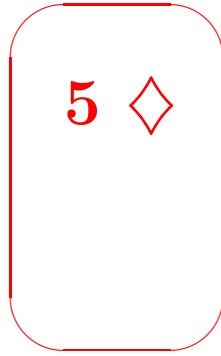
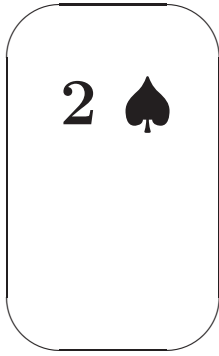
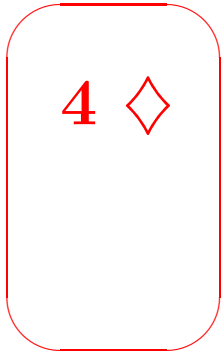
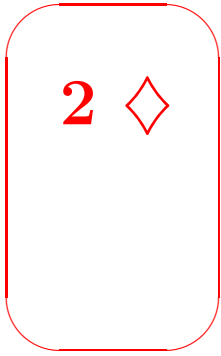

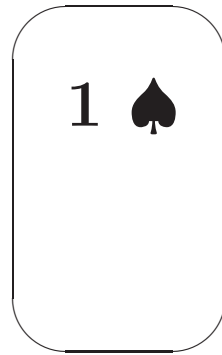
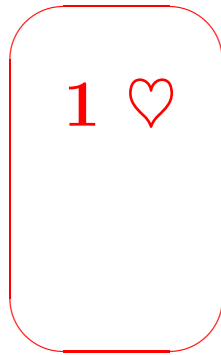
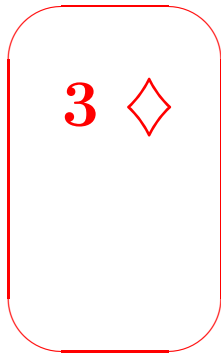
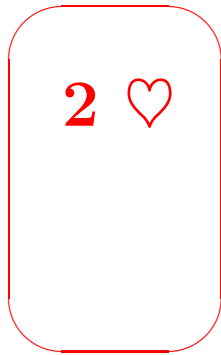
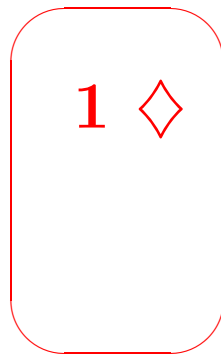
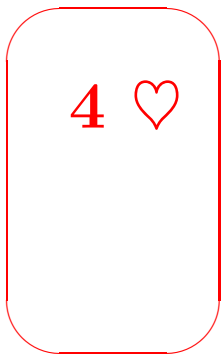
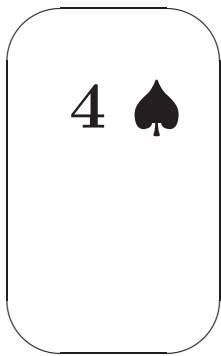
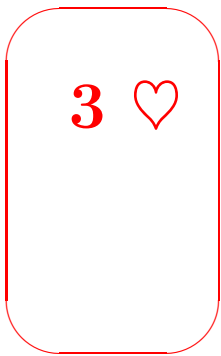
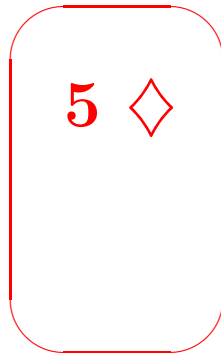
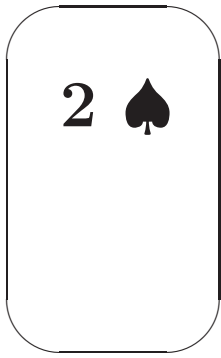
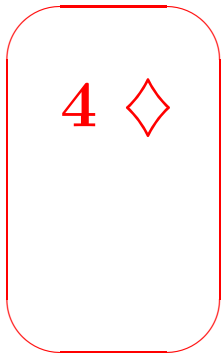
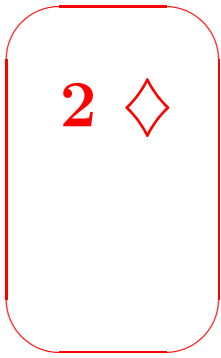

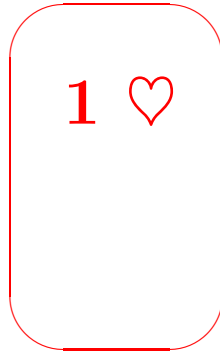
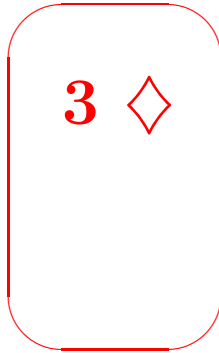
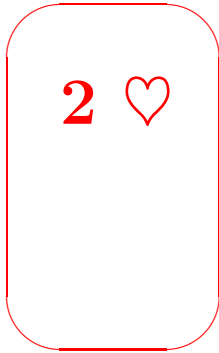
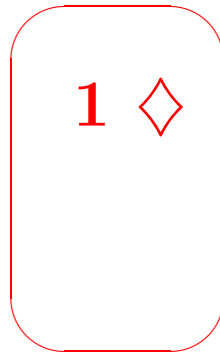
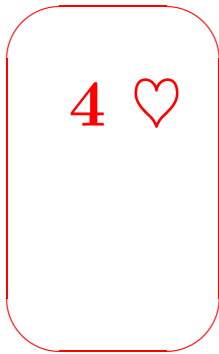
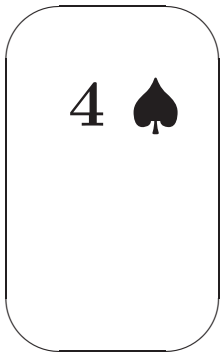
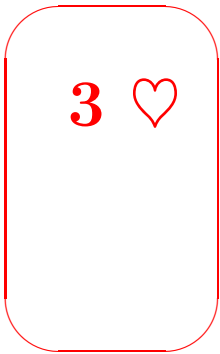
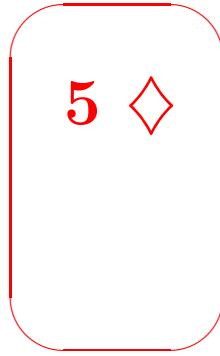
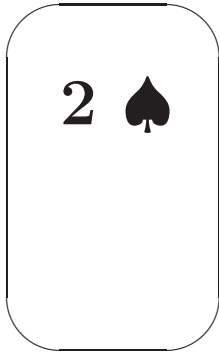
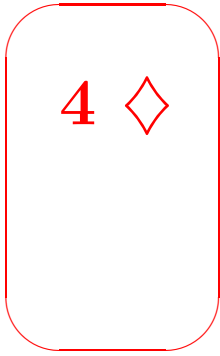
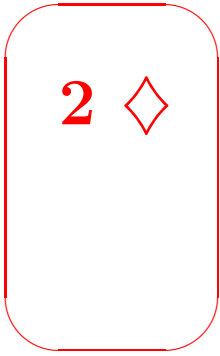

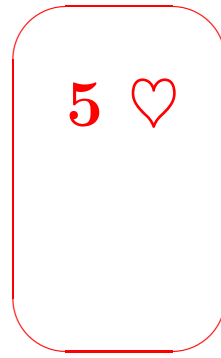
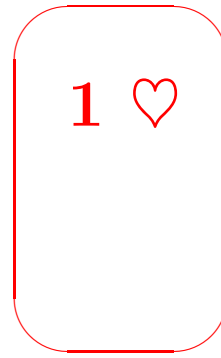
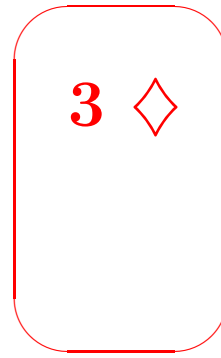
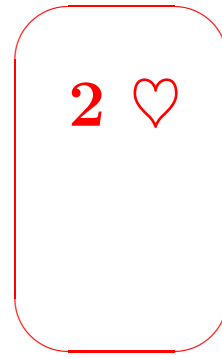
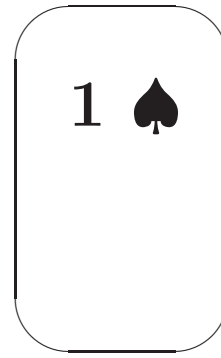
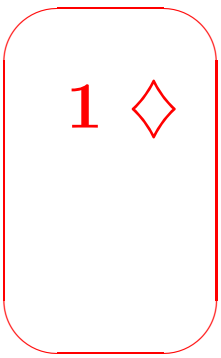
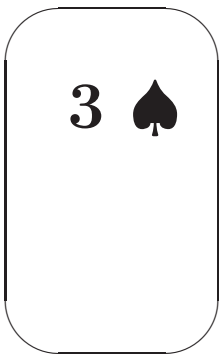
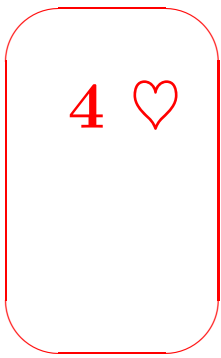
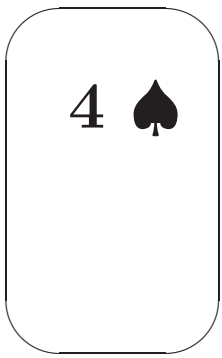
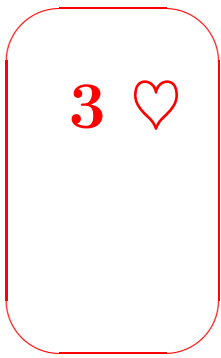
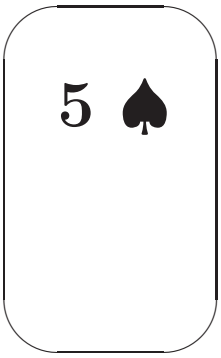
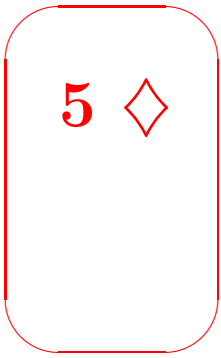
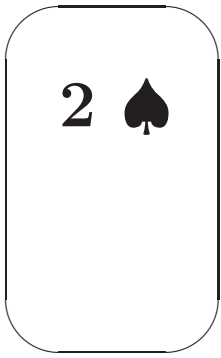
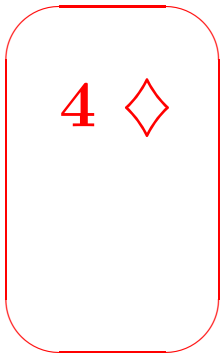
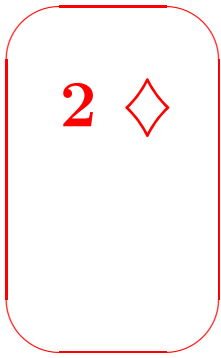

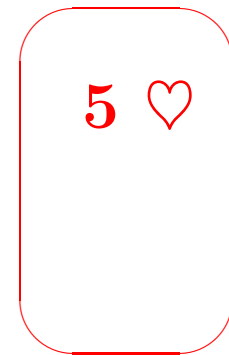
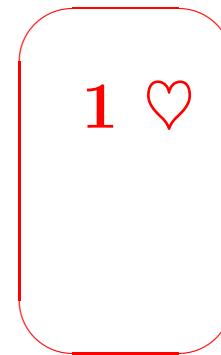
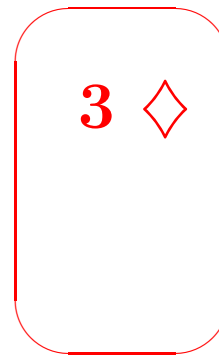
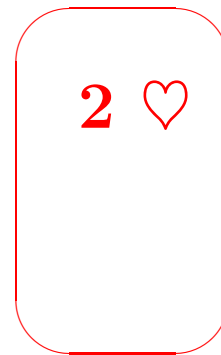
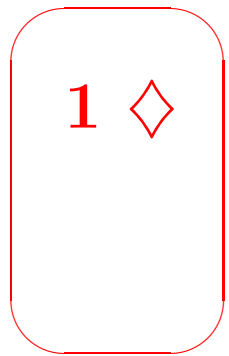
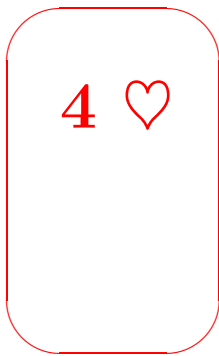
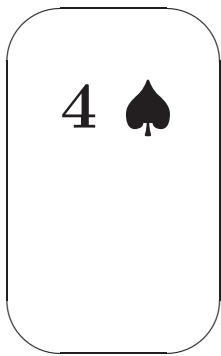
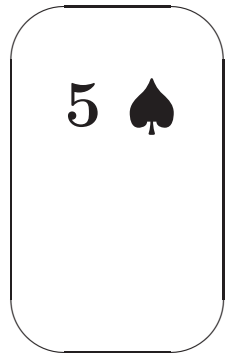
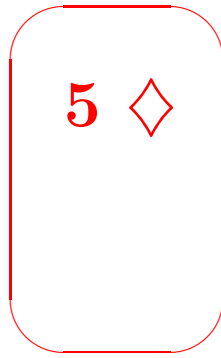
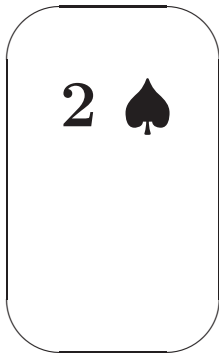
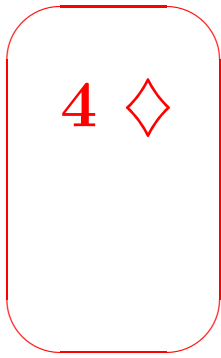

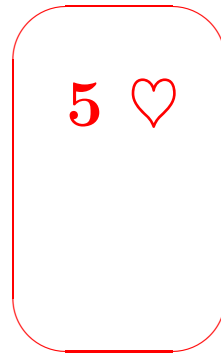
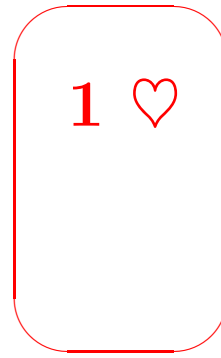
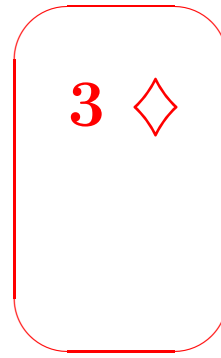
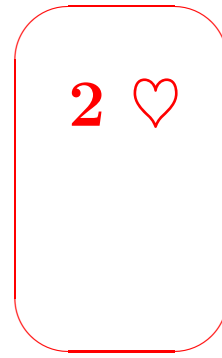
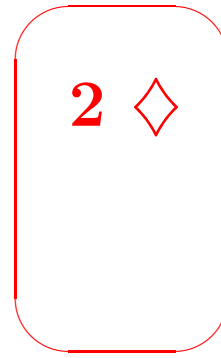
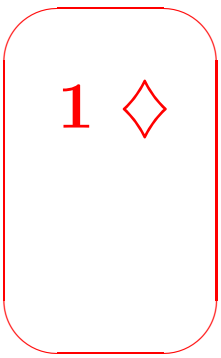
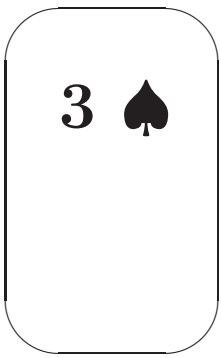
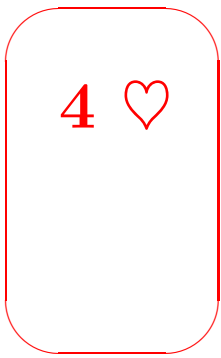
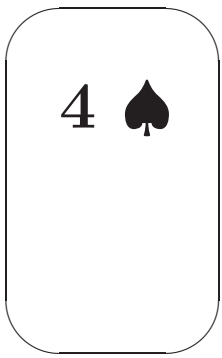
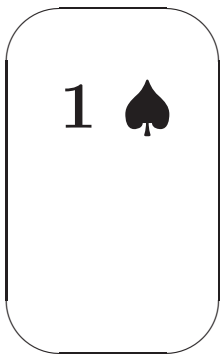
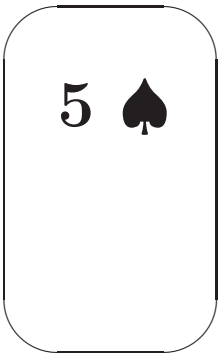
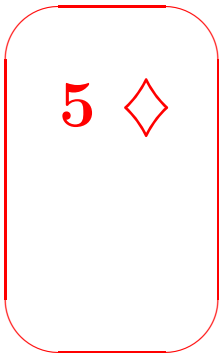
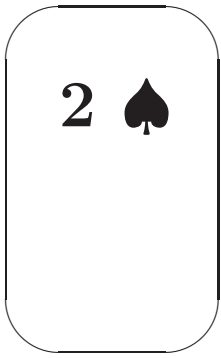
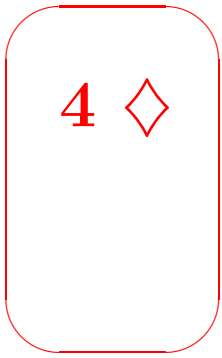
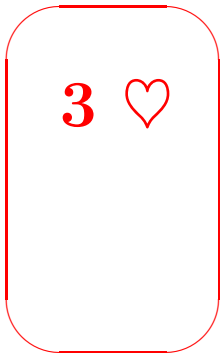

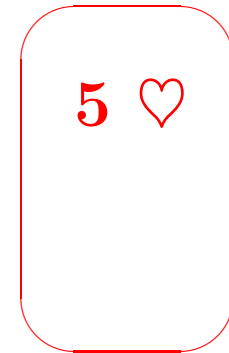
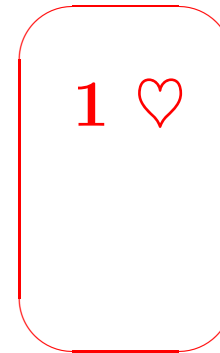
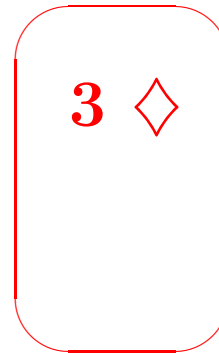
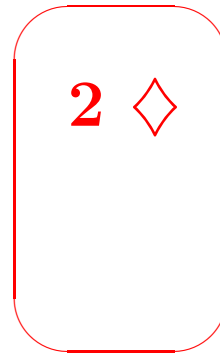
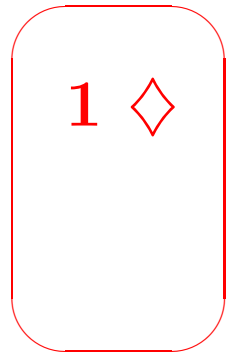
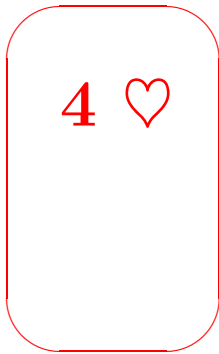
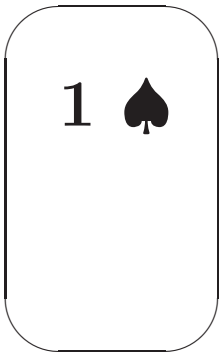
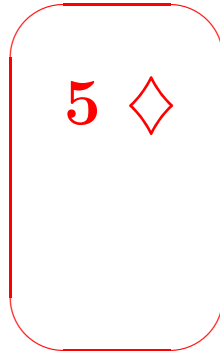
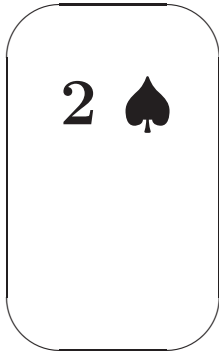
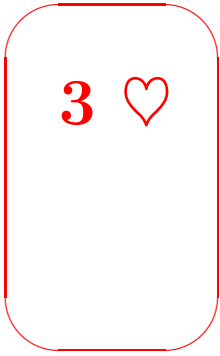

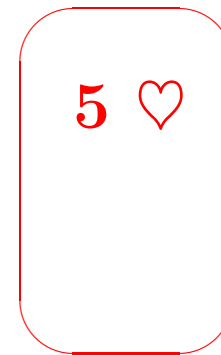
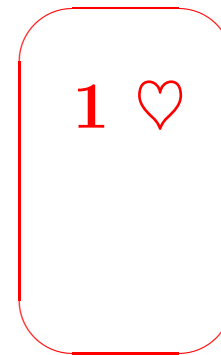
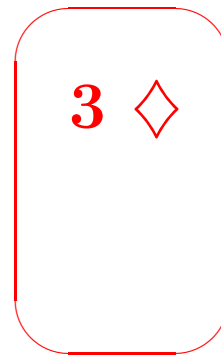
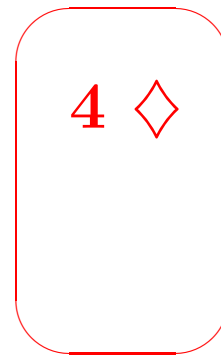
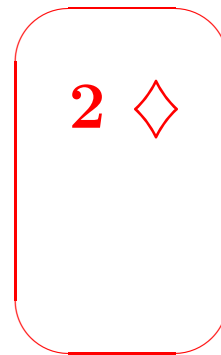
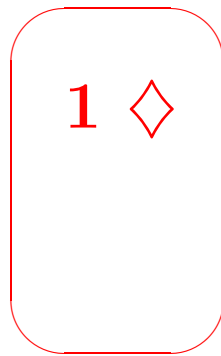
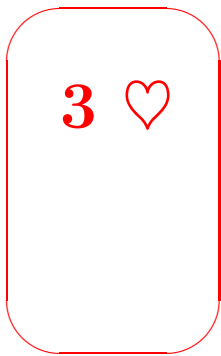
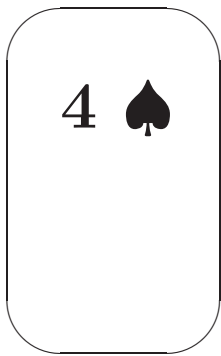
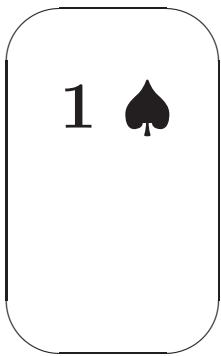
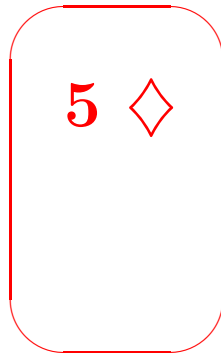
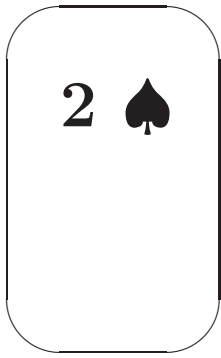
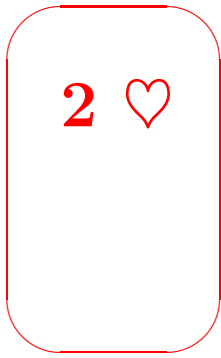
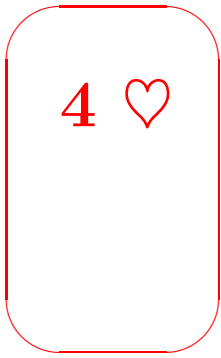

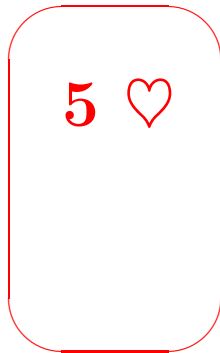
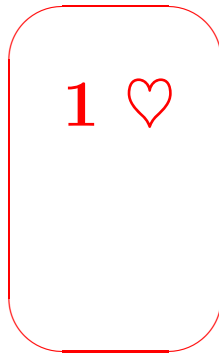
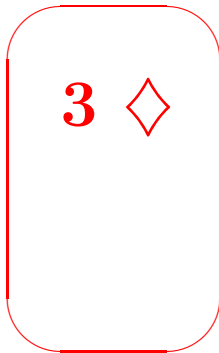
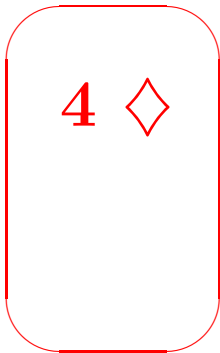
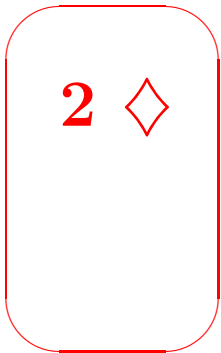
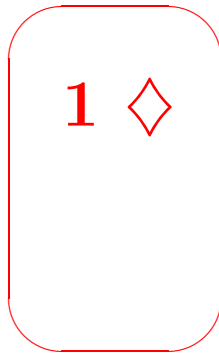
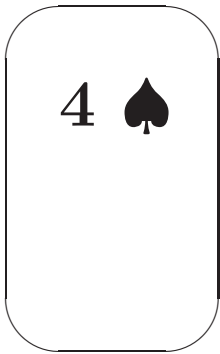
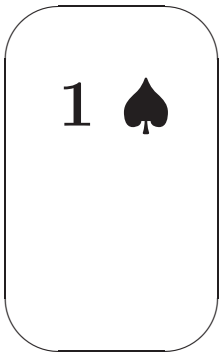
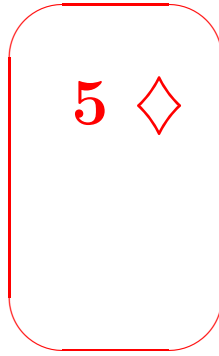
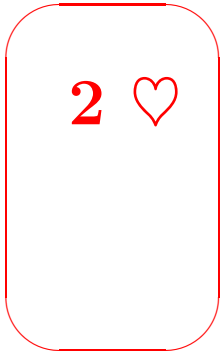
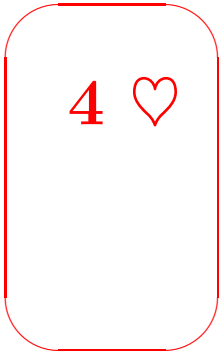

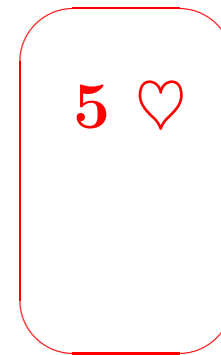
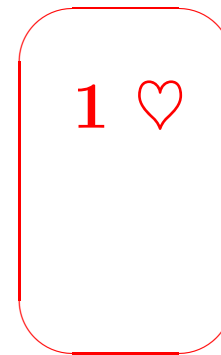
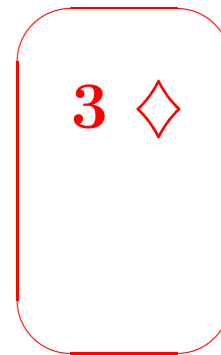
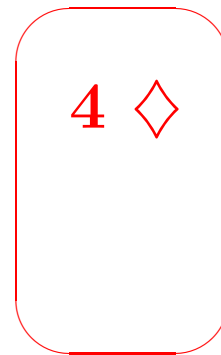
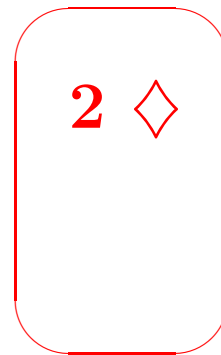
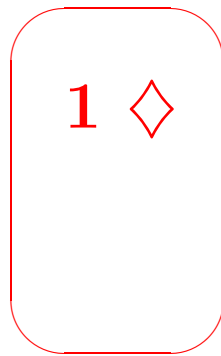
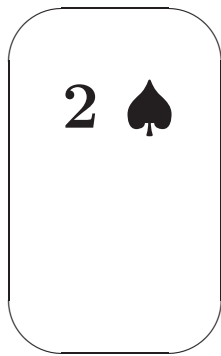
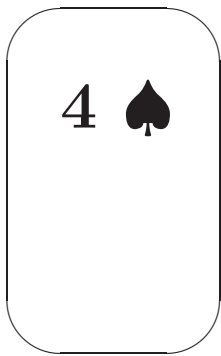
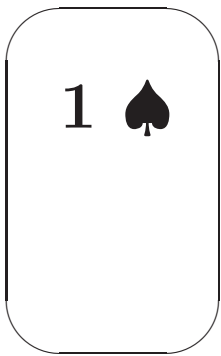
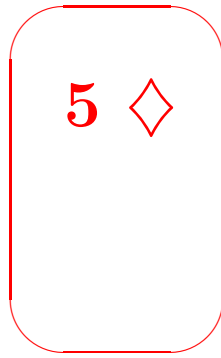
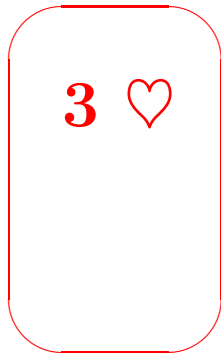
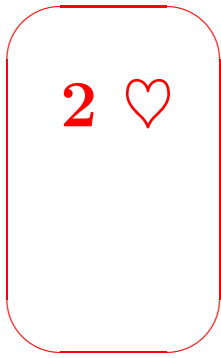
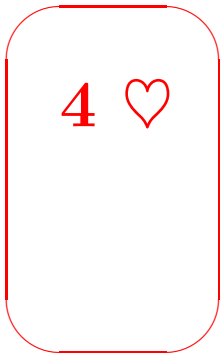

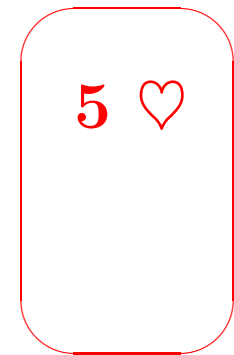
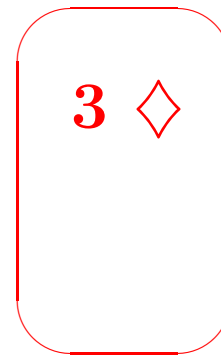
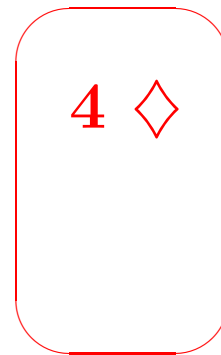
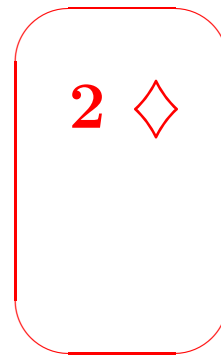
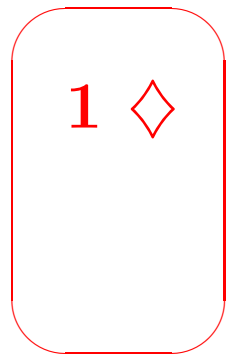
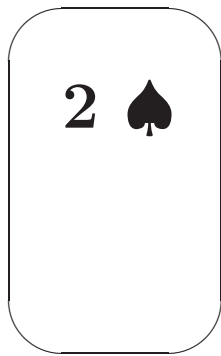
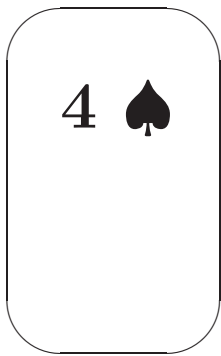
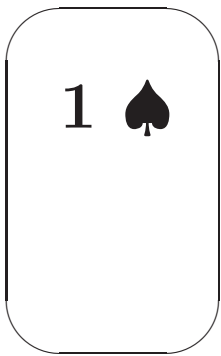
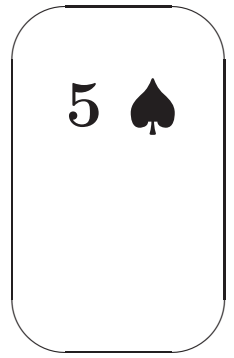
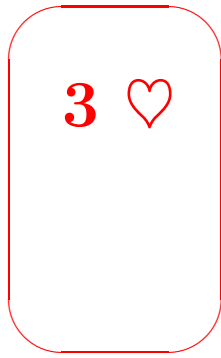
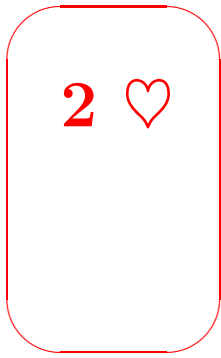
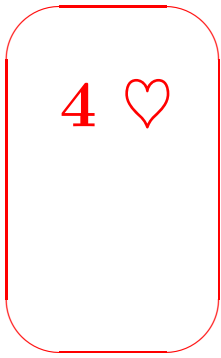

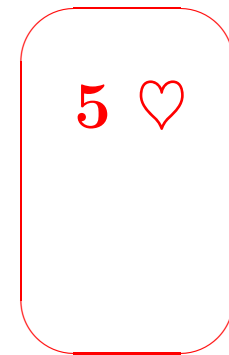
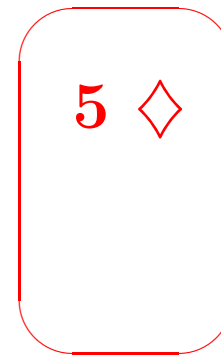
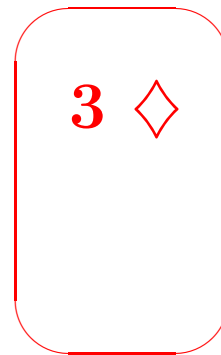
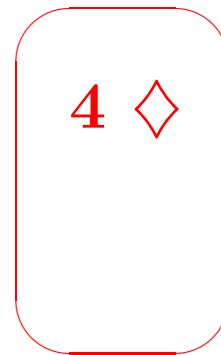
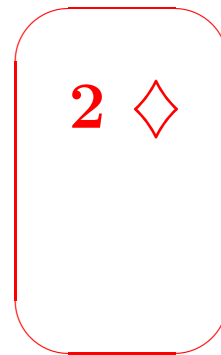
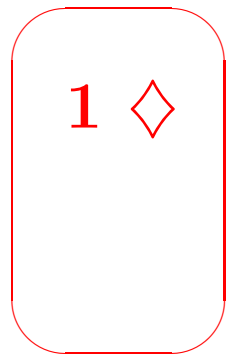
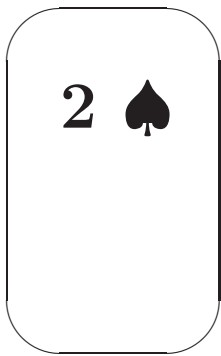
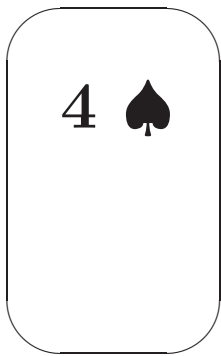
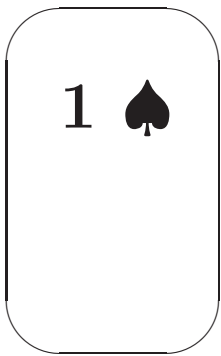
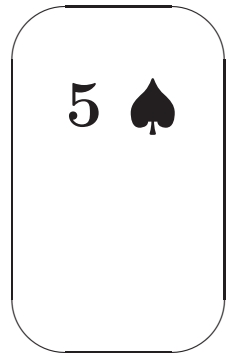
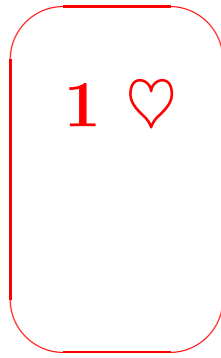
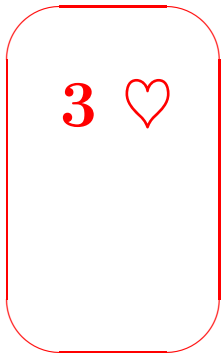
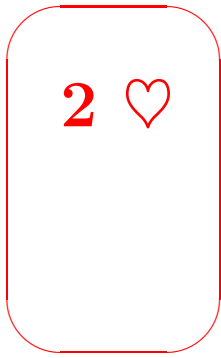
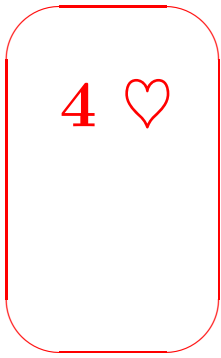

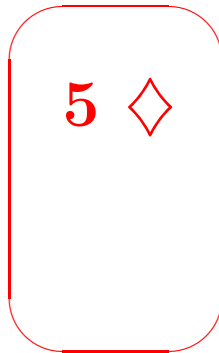
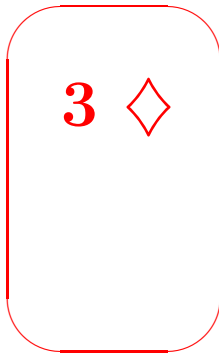
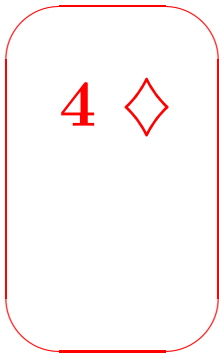
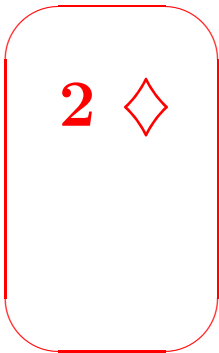
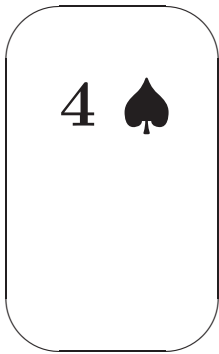
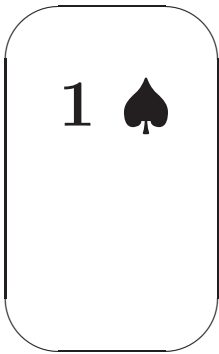
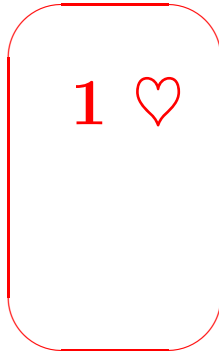
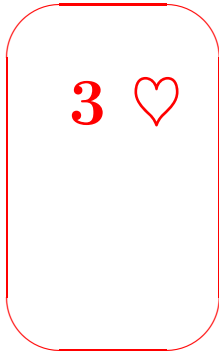
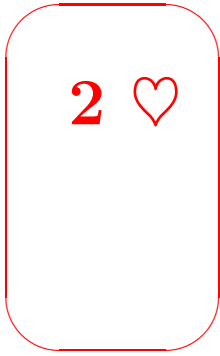
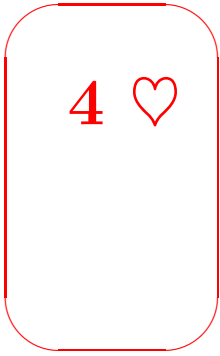

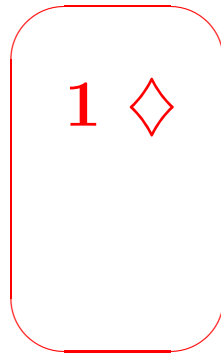
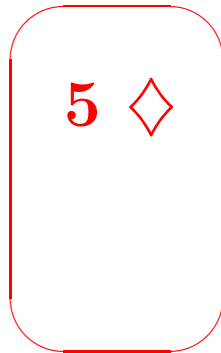
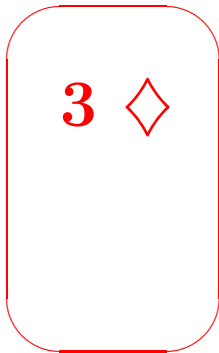
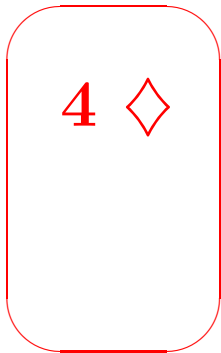
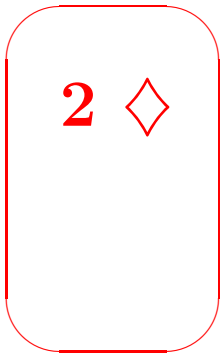
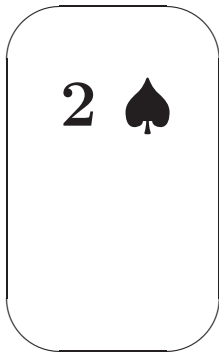
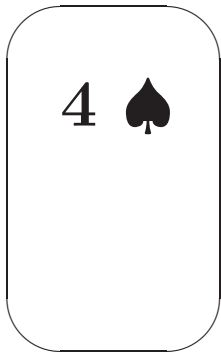
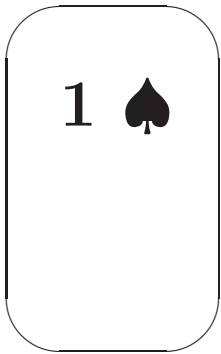
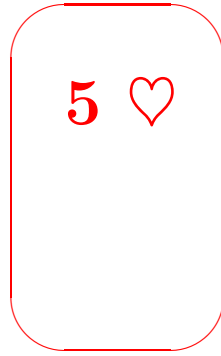
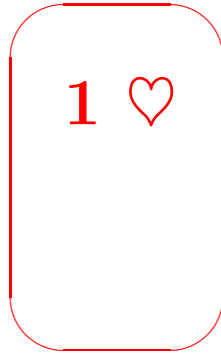
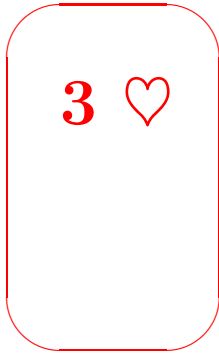
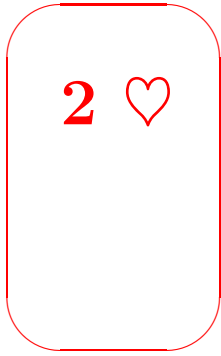
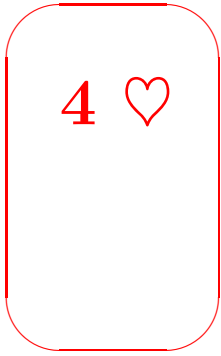

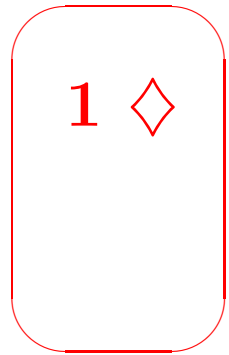
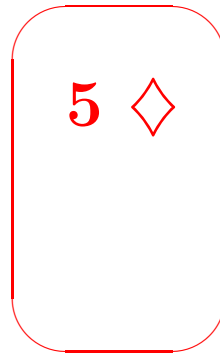
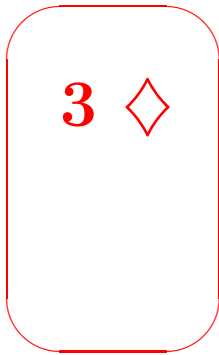
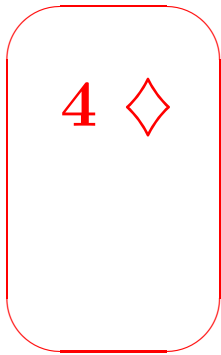
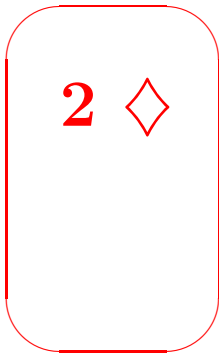
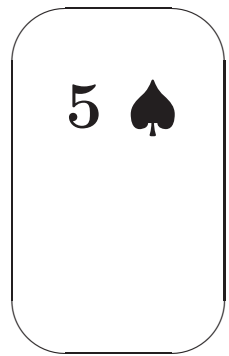
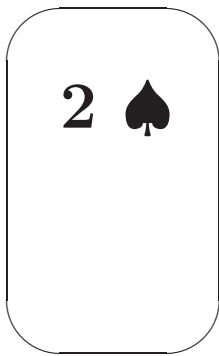
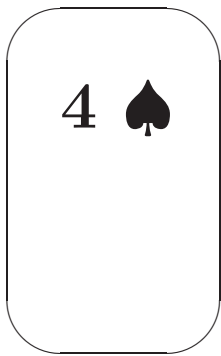
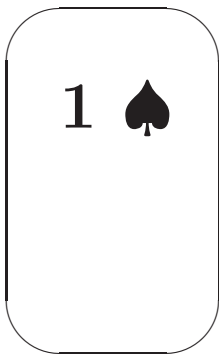
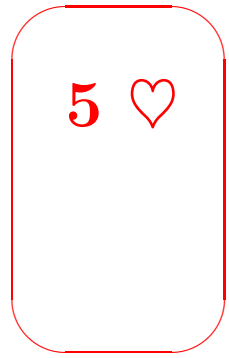
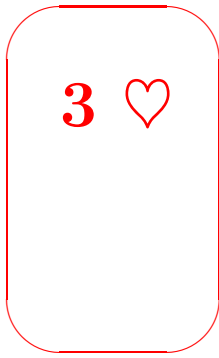
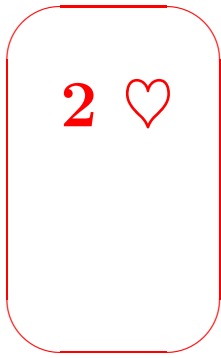

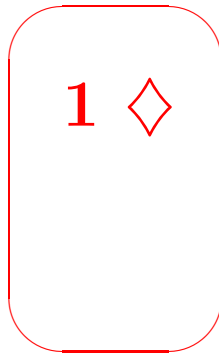
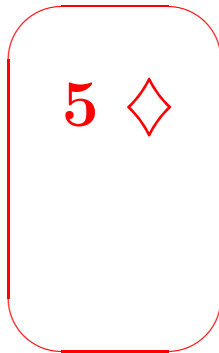
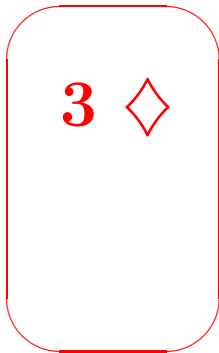
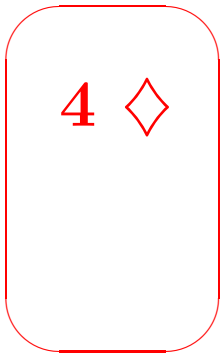
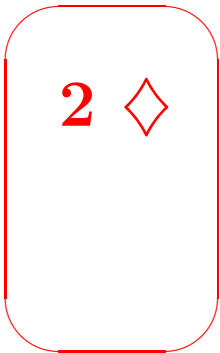
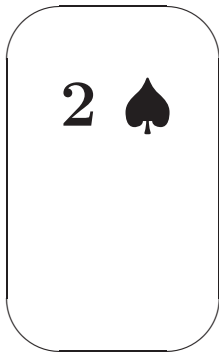
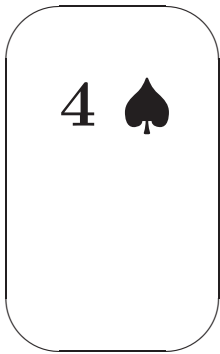
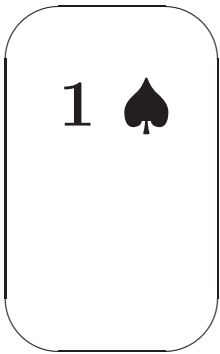
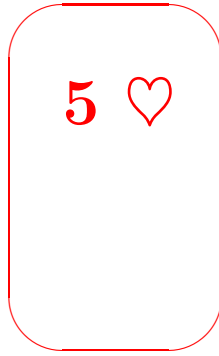
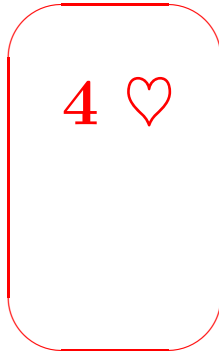
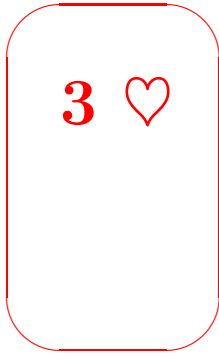
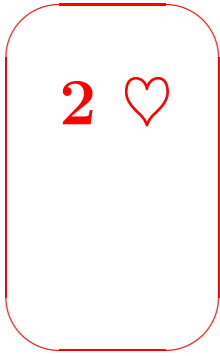
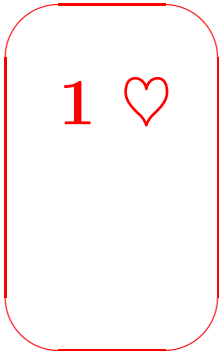

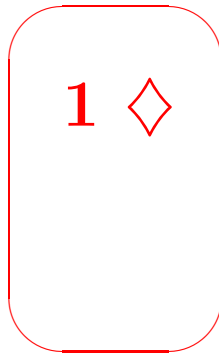
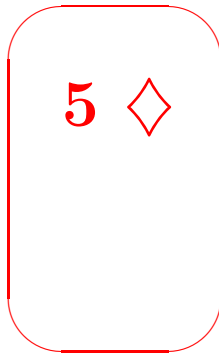
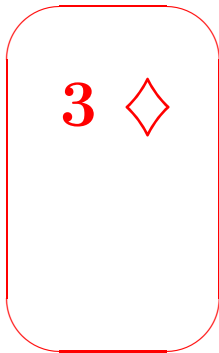
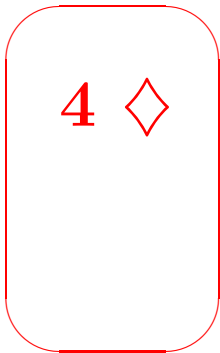
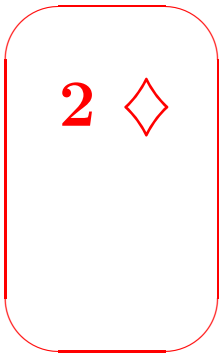
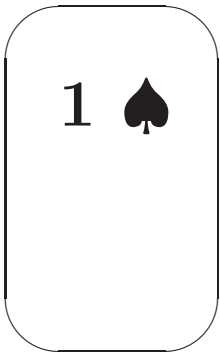
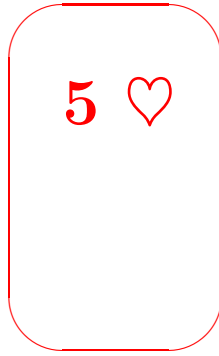
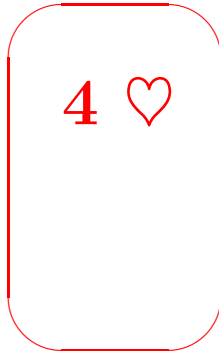
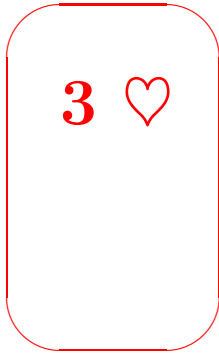
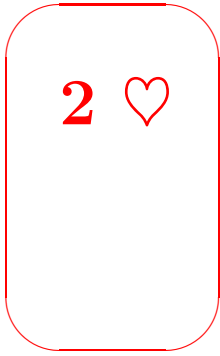
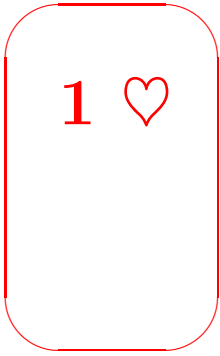

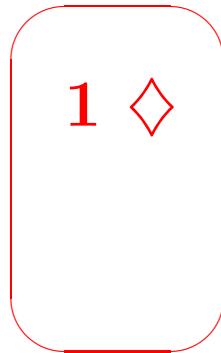
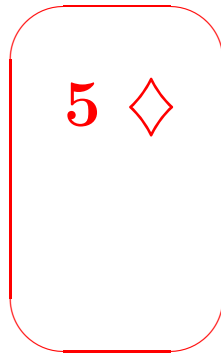
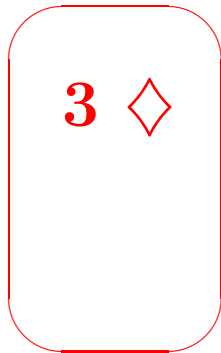
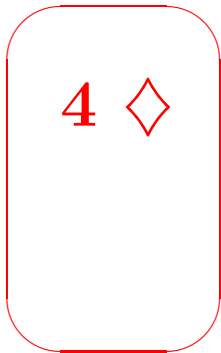
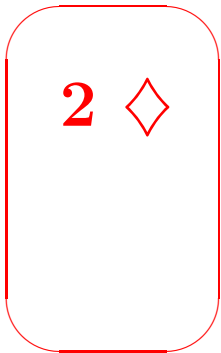
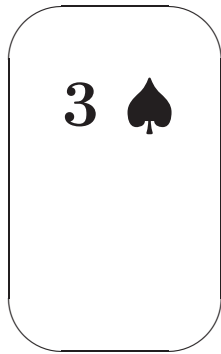
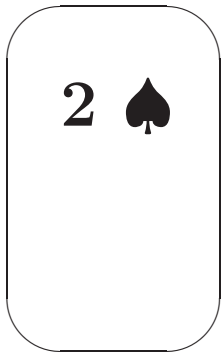
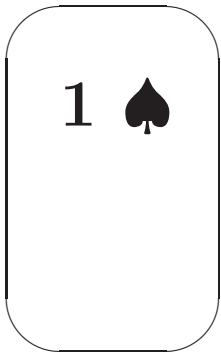
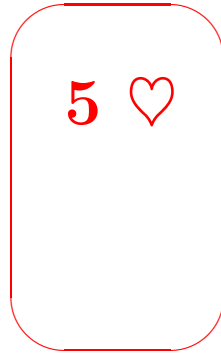
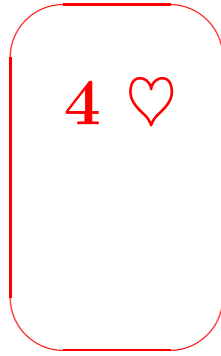
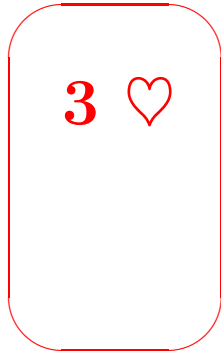
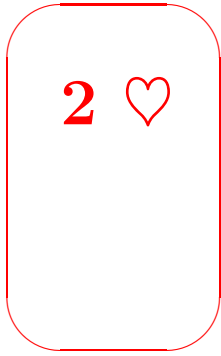
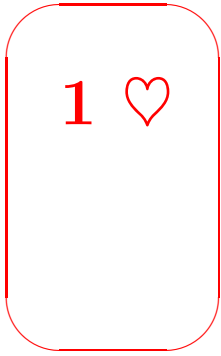

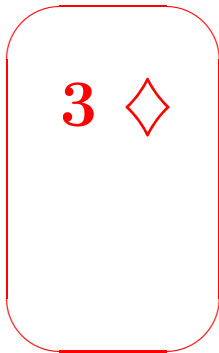
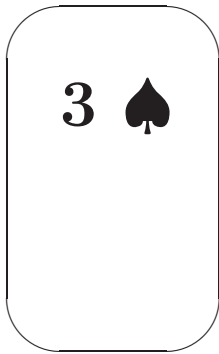
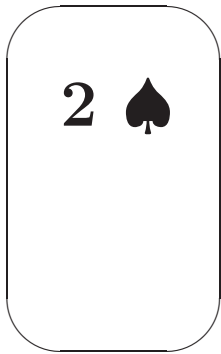
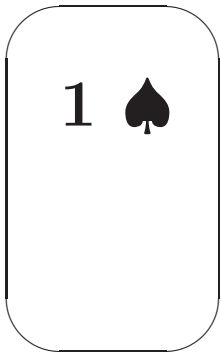
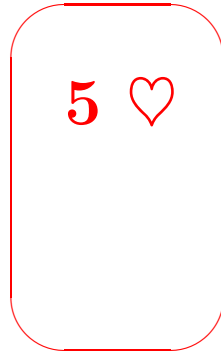
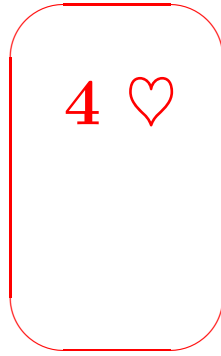
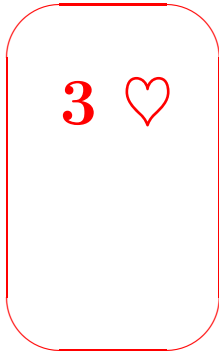
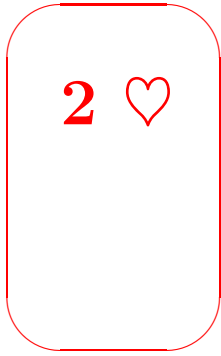
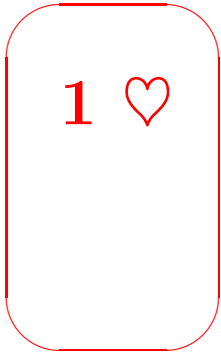

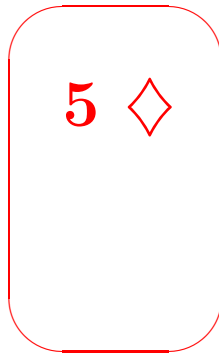
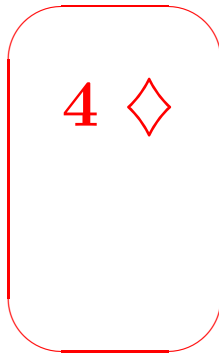
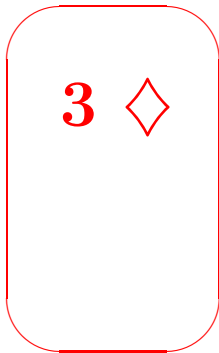
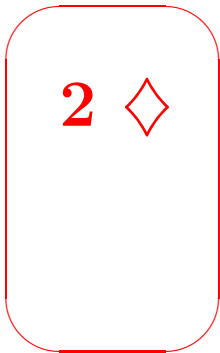
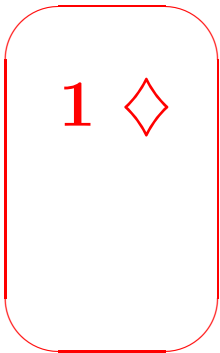
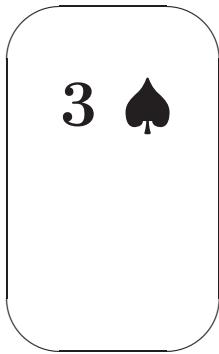
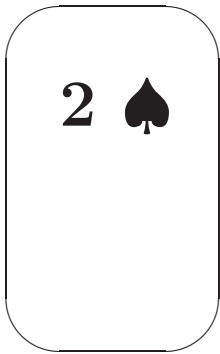
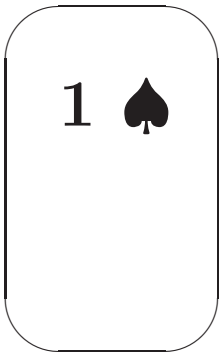
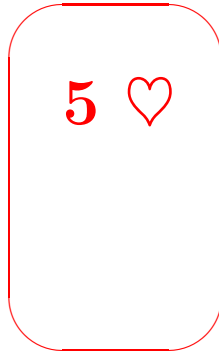
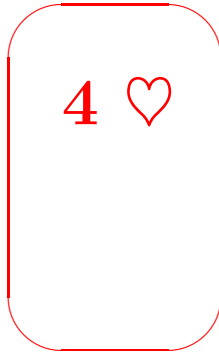
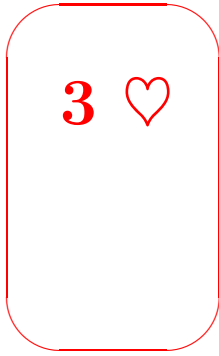
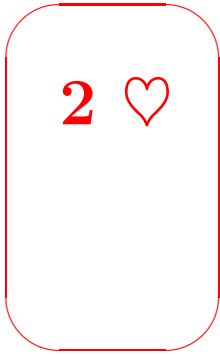
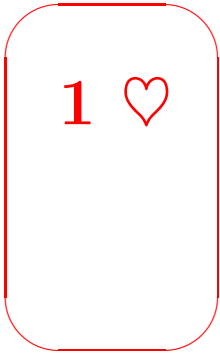

Birkhoff's theorem

An arbitrary $q \times q$ matrix
with entries $\in \{0, 1, 2, \dots, p\}$
and all line sums $= p$:

$$\begin{pmatrix} 0 & 2 & 3 \\ 2 & 2 & 1 \\ 3 & 1 & 1 \end{pmatrix}$$

Birkhoff's theorem

$$\begin{pmatrix} 0 & 2 & 3 \\ 2 & 2 & 1 \\ 3 & 1 & 1 \end{pmatrix}$$

$$= \begin{pmatrix} 0 & 1 & 0 \\ 0 & 0 & 1 \\ 1 & 0 & 0 \end{pmatrix} + \begin{pmatrix} 0 & 0 & 1 \\ 0 & 1 & 0 \\ 1 & 0 & 0 \end{pmatrix} + \begin{pmatrix} 0 & 1 & 0 \\ 1 & 0 & 0 \\ 0 & 0 & 1 \end{pmatrix} + \begin{pmatrix} 0 & 0 & 1 \\ 0 & 1 & 0 \\ 1 & 0 & 0 \end{pmatrix} + \begin{pmatrix} 0 & 0 & 1 \\ 1 & 0 & 0 \\ 0 & 1 & 0 \end{pmatrix}$$

$$n = p \times q$$

$$15 = 5 \times 3$$

A logically irreversible computer

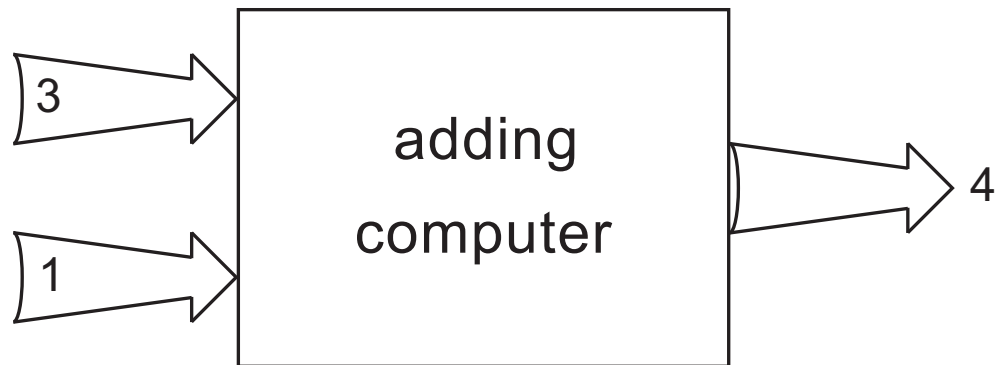

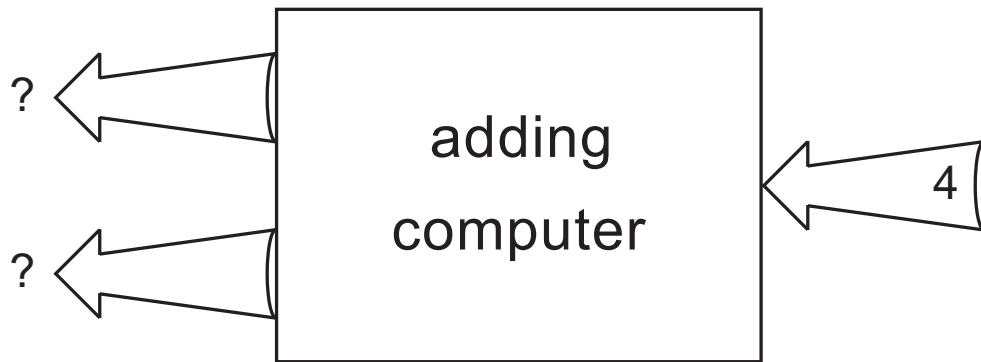
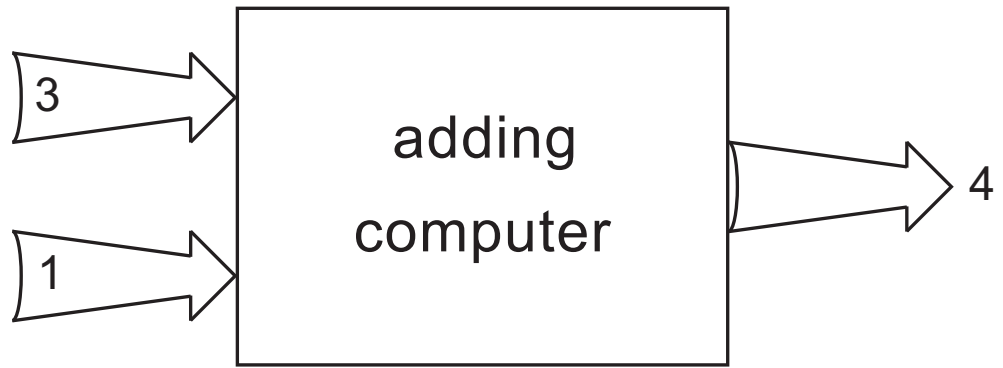

A logically reversible computer :

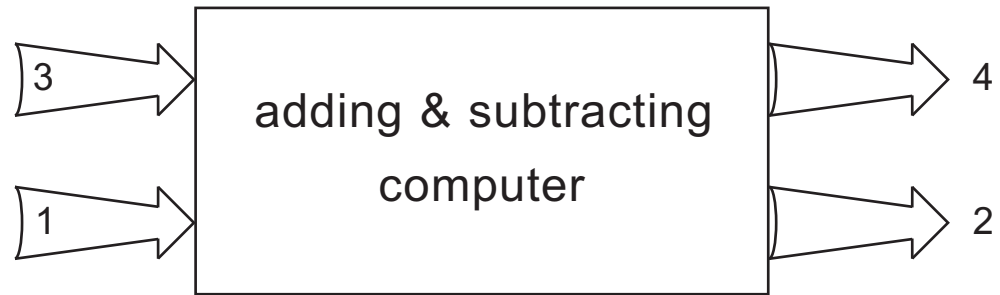

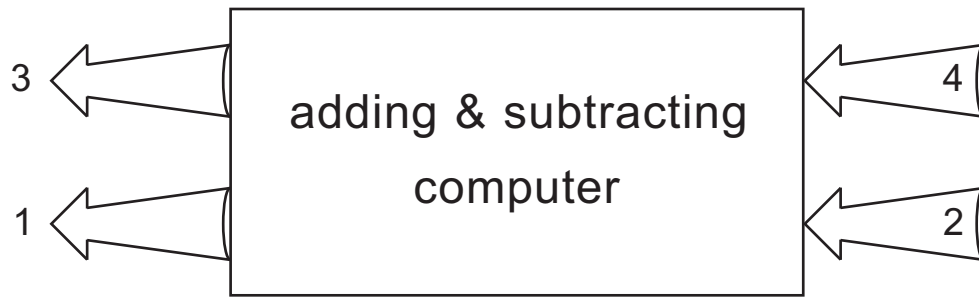
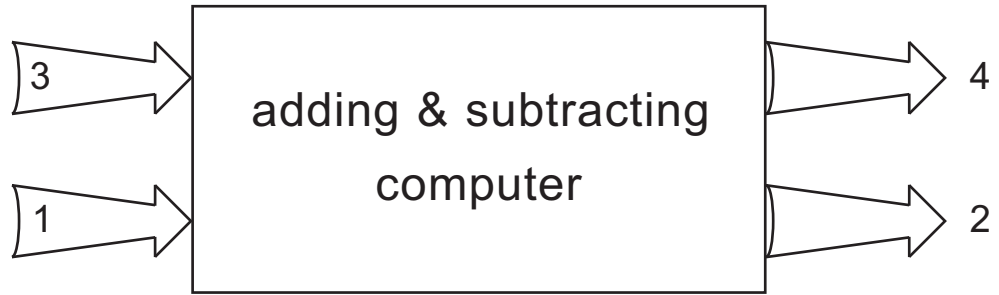

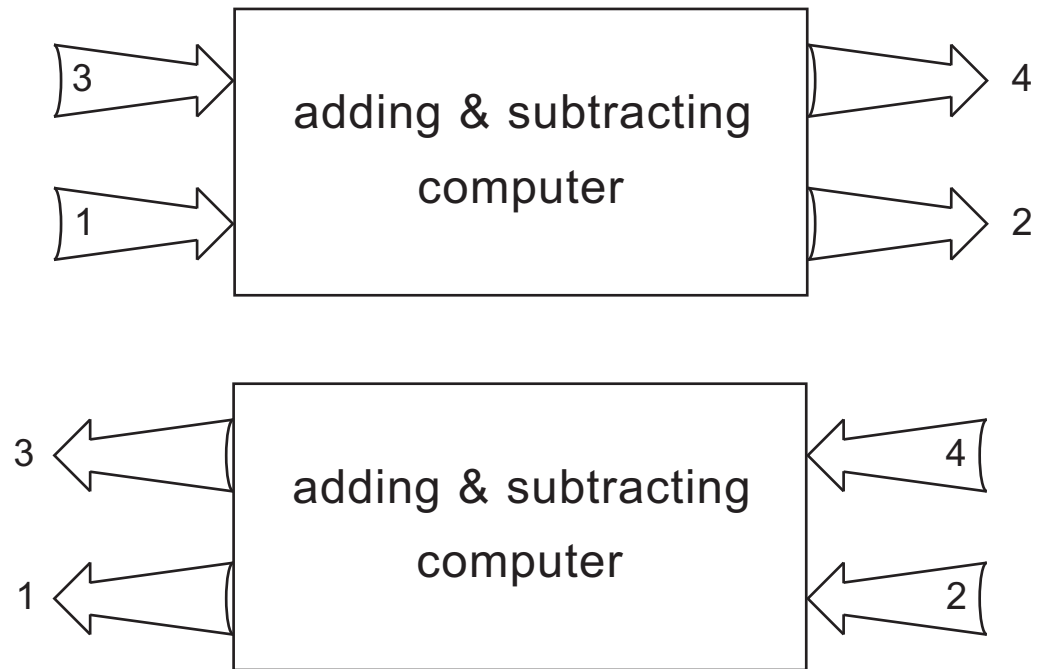

$$\begin{cases} P = A + B \\ Q = A - B \end{cases}$$

$$\Rightarrow \begin{cases} A = \frac{1}{2} P + \frac{1}{2} Q \\ B = \frac{1}{2} P - \frac{1}{2} Q \end{cases}$$

$A_1A_2A_3$	$P_1P_2P_3$
0 0 0	1 1 1
0 0 1	1 1 0
0 1 0	1 0 0
0 1 1	0 0 0
1 0 0	1 0 1
1 0 1	0 1 0
1 1 0	0 0 1
1 1 1	0 1 1

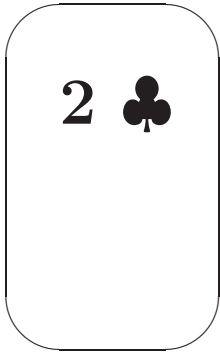
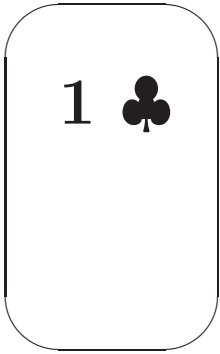
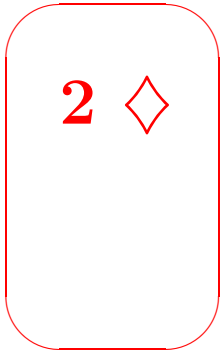
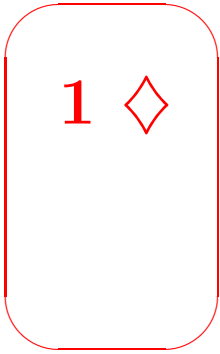
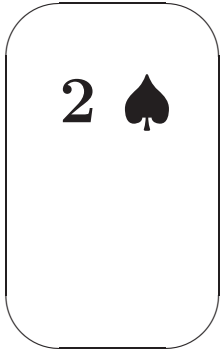
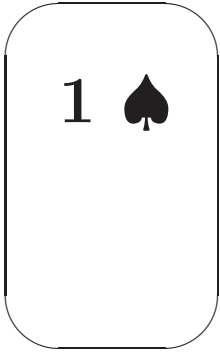
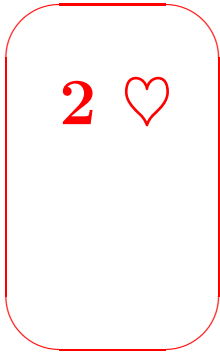
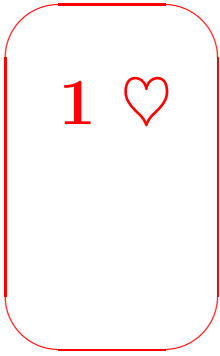

1 ♥

2 ♥

000

001

1 ♠

2 ♠

010

011

1 ♦

2 ♦

100

101

1 ♣

2 ♣

110

111

$A_1A_2A_3$	$P_1P_2P_3$
0 0 0	1 1 1
0 0 1	1 1 0
0 1 0	1 0 0
0 1 1	0 0 0
1 0 0	1 0 1
1 0 1	0 1 0
1 1 0	0 0 1
1 1 1	0 1 1

000

001

010

011

100

101

110

111

$A_1A_2A_3$	$P_1P_2P_3$
0 0 0	1 1 1
0 0 1	1 1 0
0 1 0	1 0 0
0 1 1	0 0 0
1 0 0	1 0 1
1 0 1	0 1 0
1 1 0	0 0 1
1 1 1	0 1 1

010

011

100

101

110

111

$A_1A_2A_3$	$P_1P_2P_3$
0 0 0	1 1 1
0 0 1	1 1 0
0 1 0	1 0 0
0 1 1	0 0 0
1 0 0	1 0 1
1 0 1	0 1 0
1 1 0	0 0 1
1 1 1	0 1 1

001

000

010

011

100

101

110

111

$A_1A_2A_3$	$P_1P_2P_3$
0 0 0	1 1 1
0 0 1	1 1 0
0 1 0	1 0 0
0 1 1	0 0 0
1 0 0	1 0 1
1 0 1	0 1 0
1 1 0	0 0 1
1 1 1	0 1 1

001

000

010

011

100

101

$A_1A_2A_3$	$P_1P_2P_3$
0 0 0	1 1 1
0 0 1	1 1 0
0 1 0	1 0 0
0 1 1	0 0 0
1 0 0	1 0 1
1 0 1	0 1 0
1 1 0	0 0 1
1 1 1	0 1 1

001

000

010

011

100

101

111

110

$A_1A_2A_3$	$P_1P_2P_3$
0 0 0	1 1 1
0 0 1	1 1 0
0 1 0	1 0 0
0 1 1	0 0 0
1 0 0	1 0 1
1 0 1	0 1 0
1 1 0	0 0 1
1 1 1	0 1 1

000

011

101

110

$A_1A_2A_3$	$P_1P_2P_3$
0 0 0	1 1 1
0 0 1	1 1 0
0 1 0	1 0 0
0 1 1	0 0 0
1 0 0	1 0 1
1 0 1	0 1 0
1 1 0	0 0 1
1 1 1	0 1 1

111

000

100

011

010

101

001

110

$A_1A_2A_3$	$P_1P_2P_3$
0 0 0	1 1 1
0 0 1	1 1 0
0 1 0	1 0 0
0 1 1	0 0 0
1 0 0	1 0 1
1 0 1	0 1 0
1 1 0	0 0 1
1 1 1	0 1 1

111

100

010

101

001

$A_1A_2A_3$	$P_1P_2P_3$
0 0 0	1 1 1
0 0 1	1 1 0
0 1 0	1 0 0
0 1 1	0 0 0
1 0 0	1 0 1
1 0 1	0 1 0
1 1 0	0 0 1
1 1 1	0 1 1

111

110

100

000

010

101

001

011

$A_1A_2A_3$	$P_1P_2P_3$
0 0 0	1 1 1
0 0 1	1 1 0
0 1 0	1 0 0
0 1 1	0 0 0
1 0 0	1 0 1
1 0 1	0 1 0
1 1 0	0 0 1
1 1 1	0 1 1

111

110

100

000

001

011

$A_1A_2A_3$	$P_1P_2P_3$
0 0 0	1 1 1
0 0 1	1 1 0
0 1 0	1 0 0
0 1 1	0 0 0
1 0 0	1 0 1
1 0 1	0 1 0
1 1 0	0 0 1
1 1 1	0 1 1

111

110

100

000

101

010

001

011

a

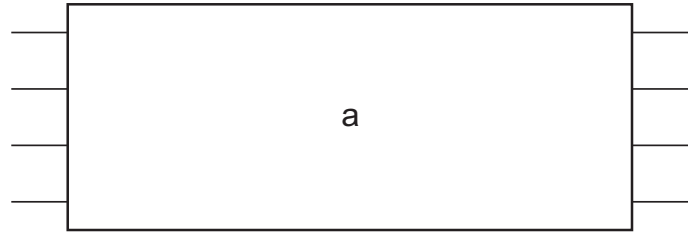

b

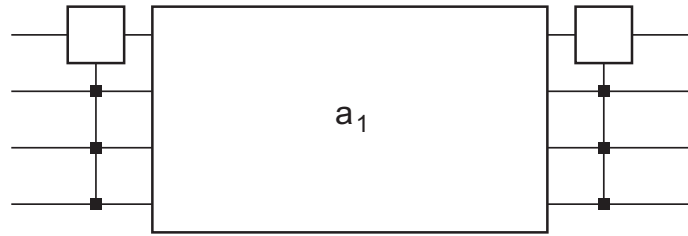

c

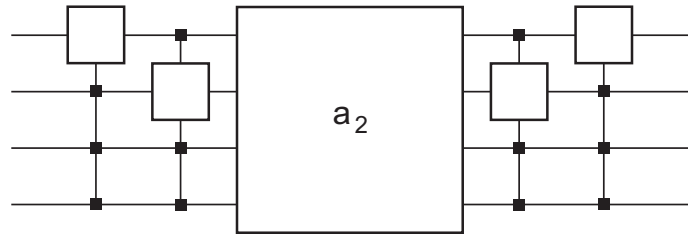

d

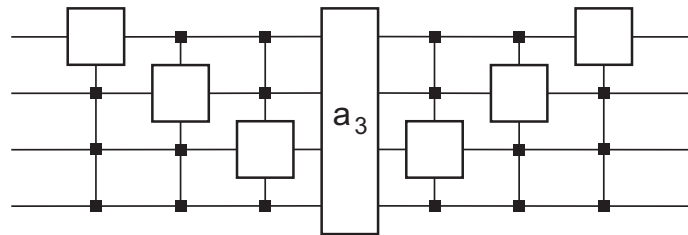

e

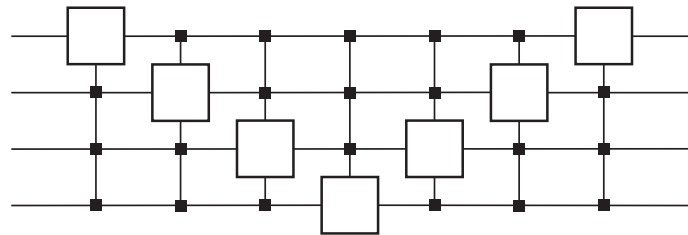

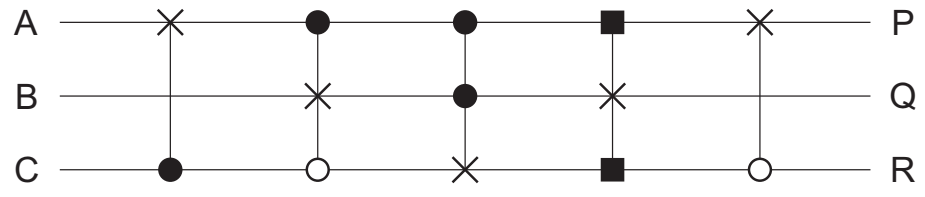

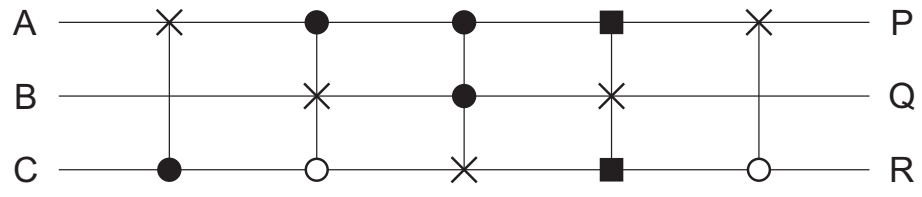

$$2^{2^w-1}$$

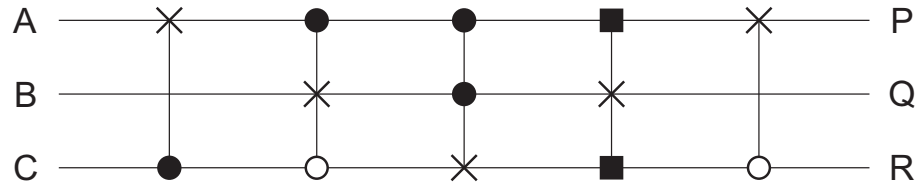

$$2^{2^w-1} \times 2^{2^w-1}$$

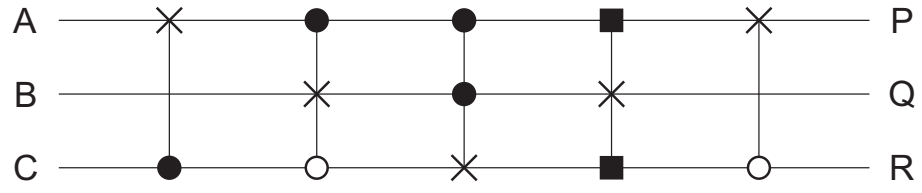

$$2^{2^{w-1}} \times 2^{2^{w-1}} \times \dots \times 2^{2^{w-1}}$$

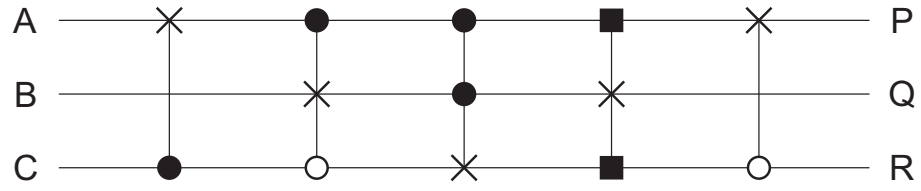

$$2^{2^{w-1}} \times 2^{2^{w-1}} \times \dots \times 2^{2^{w-1}}$$

$$= \left(2^{2^{w-1}}\right)^{2^{w-1}} = 2^{(w-\frac{1}{2})2^w}$$

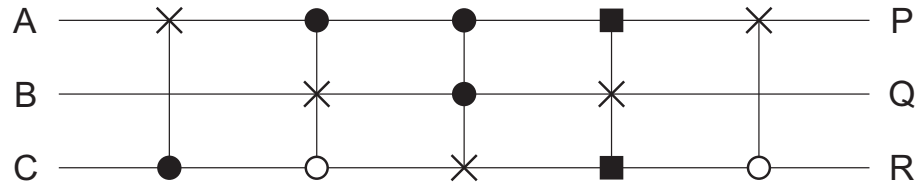

$$2^{2^{w-1}} \times 2^{2^{w-1}} \times \dots \times 2^{2^{w-1}}$$

$$= \left(2^{2^{w-1}}\right)^{2^{w-1}} = 2^{(w-\frac{1}{2})2^w}$$

$$> (2^w)! \approx 2^{(w-\log(2))2^w}$$

Reversible truth tables of width 3

(a) an arbitrary reversible circuit

(b) control gate

$A_1A_2A_3$	$P_1P_2P_3$
0 0 0	1 1 1
0 0 1	1 1 0
0 1 0	1 0 0
0 1 1	0 0 0
1 0 0	1 0 1
1 0 1	0 1 0
1 1 0	0 0 1
1 1 1	0 1 1

(a)

$A_1A_2A_3$	$P_1P_2P_3$
0 0 0	0 0 1
0 0 1	0 0 0
0 1 0	0 1 0
0 1 1	0 1 1
1 0 0	1 0 1
1 0 1	1 0 0
1 1 0	1 1 1
1 1 1	1 1 0

(b)

$$\begin{pmatrix} 0 & 0 & 0 & 0 & 0 & 0 & 0 & 1 \\ 0 & 0 & 0 & 0 & 0 & 0 & 1 & 0 \\ 0 & 0 & 0 & 0 & 1 & 0 & 0 & 0 \\ 1 & 0 & 0 & 0 & 0 & 0 & 0 & 0 \\ 0 & 0 & 0 & 0 & 0 & 1 & 0 & 0 \\ 0 & 0 & 1 & 0 & 0 & 0 & 0 & 0 \\ 0 & 1 & 0 & 0 & 0 & 0 & 0 & 0 \\ 0 & 0 & 0 & 1 & 0 & 0 & 0 & 0 \end{pmatrix}$$

$$\begin{pmatrix} 0 & 1 & 0 & 0 & 0 & 0 & 0 & 0 \\ 1 & 0 & 0 & 0 & 0 & 0 & 0 & 0 \\ 0 & 0 & 1 & 0 & 0 & 0 & 0 & 0 \\ 0 & 0 & 0 & 1 & 0 & 0 & 0 & 0 \\ 0 & 0 & 0 & 0 & 0 & 1 & 0 & 0 \\ 0 & 0 & 0 & 0 & 1 & 0 & 0 & 0 \\ 0 & 0 & 0 & 0 & 0 & 0 & 0 & 1 \\ 0 & 0 & 0 & 0 & 0 & 0 & 1 & 0 \end{pmatrix}$$

$$\begin{pmatrix} 0 & 0 & 0 & 0 & 0 & 0 & 0 & 1 \\ 0 & 0 & 0 & 0 & 0 & 0 & 1 & 0 \\ 0 & 0 & 0 & 0 & 1 & 0 & 0 & 0 \\ 1 & 0 & 0 & 0 & 0 & 0 & 0 & 0 \\ 0 & 0 & 0 & 0 & 0 & 1 & 0 & 0 \\ 0 & 0 & 1 & 0 & 0 & 0 & 0 & 0 \\ 0 & 1 & 0 & 0 & 0 & 0 & 0 & 0 \\ 0 & 0 & 0 & 1 & 0 & 0 & 0 & 0 \end{pmatrix}$$

$$\begin{pmatrix} 0 & 1 & 0 & 0 & 0 & 0 & 0 & 0 \\ 1 & 0 & 0 & 0 & 0 & 0 & 0 & 0 \\ 0 & 0 & 1 & 0 & 0 & 0 & 0 & 0 \\ 0 & 0 & 0 & 1 & 0 & 0 & 0 & 0 \\ 0 & 0 & 0 & 0 & 0 & 1 & 0 & 0 \\ 0 & 0 & 0 & 0 & 1 & 0 & 0 & 0 \\ 0 & 0 & 0 & 0 & 0 & 0 & 0 & 1 \\ 0 & 0 & 0 & 0 & 0 & 0 & 1 & 0 \end{pmatrix}$$

$$\begin{pmatrix} U_{11} & U_{12} & U_{13} & U_{14} & U_{15} & U_{16} & U_{17} & U_{18} \\ U_{21} & U_{22} & U_{23} & U_{24} & U_{25} & U_{26} & U_{27} & U_{28} \\ U_{31} & U_{32} & U_{33} & U_{34} & U_{35} & U_{36} & U_{37} & U_{38} \\ U_{41} & U_{42} & U_{43} & U_{44} & U_{45} & U_{46} & U_{47} & U_{48} \\ U_{51} & U_{52} & U_{53} & U_{54} & U_{55} & U_{56} & U_{57} & U_{58} \\ U_{61} & U_{62} & U_{63} & U_{64} & U_{65} & U_{66} & U_{67} & U_{68} \\ U_{71} & U_{72} & U_{73} & U_{74} & U_{75} & U_{76} & U_{77} & U_{78} \\ U_{81} & U_{82} & U_{83} & U_{84} & U_{85} & U_{86} & U_{78} & U_{88} \end{pmatrix} \begin{pmatrix} U_{11} & U_{12} & 0 & 0 & 0 & 0 & 0 & 0 \\ U_{21} & U_{22} & 0 & 0 & 0 & 0 & 0 & 0 \\ 0 & 0 & U_{33} & U_{34} & 0 & 0 & 0 & 0 \\ 0 & 0 & U_{43} & U_{44} & 0 & 0 & 0 & 0 \\ 0 & 0 & 0 & 0 & U_{55} & U_{56} & 0 & 0 \\ 0 & 0 & 0 & 0 & U_{65} & U_{66} & 0 & 0 \\ 0 & 0 & 0 & 0 & 0 & 0 & U_{77} & U_{78} \\ 0 & 0 & 0 & 0 & 0 & 0 & U_{87} & U_{88} \end{pmatrix}$$

$n!$

$$\begin{pmatrix} 0 & 0 & 0 & 0 & 0 & 0 & 0 & 1 \\ 0 & 0 & 0 & 0 & 0 & 0 & 1 & 0 \\ 0 & 0 & 0 & 0 & 1 & 0 & 0 & 0 \\ 1 & 0 & 0 & 0 & 0 & 0 & 0 & 0 \\ 0 & 0 & 0 & 0 & 0 & 1 & 0 & 0 \\ 0 & 0 & 1 & 0 & 0 & 0 & 0 & 0 \\ 0 & 1 & 0 & 0 & 0 & 0 & 0 & 0 \\ 0 & 0 & 0 & 1 & 0 & 0 & 0 & 0 \end{pmatrix}$$

 $2^{n/2}$

$$\begin{pmatrix} 0 & 1 & 0 & 0 & 0 & 0 & 0 & 0 \\ 1 & 0 & 0 & 0 & 0 & 0 & 0 & 0 \\ 0 & 0 & 1 & 0 & 0 & 0 & 0 & 0 \\ 0 & 0 & 0 & 1 & 0 & 0 & 0 & 0 \\ 0 & 0 & 0 & 0 & 0 & 1 & 0 & 0 \\ 0 & 0 & 0 & 0 & 1 & 0 & 0 & 0 \\ 0 & 0 & 0 & 0 & 0 & 0 & 0 & 1 \\ 0 & 0 & 0 & 0 & 0 & 0 & 1 & 0 \end{pmatrix}$$

$$\begin{pmatrix} U_{11} & U_{12} & U_{13} & U_{14} & U_{15} & U_{16} & U_{17} & U_{18} \\ U_{21} & U_{22} & U_{23} & U_{24} & U_{25} & U_{26} & U_{27} & U_{28} \\ U_{31} & U_{32} & U_{33} & U_{34} & U_{35} & U_{36} & U_{37} & U_{38} \\ U_{41} & U_{42} & U_{43} & U_{44} & U_{45} & U_{46} & U_{47} & U_{48} \\ U_{51} & U_{52} & U_{53} & U_{54} & U_{55} & U_{56} & U_{57} & U_{58} \\ U_{61} & U_{62} & U_{63} & U_{64} & U_{65} & U_{66} & U_{67} & U_{68} \\ U_{71} & U_{72} & U_{73} & U_{74} & U_{75} & U_{76} & U_{77} & U_{78} \\ U_{81} & U_{82} & U_{83} & U_{84} & U_{85} & U_{86} & U_{78} & U_{88} \end{pmatrix} \begin{pmatrix} U_{11} & U_{12} & 0 & 0 & 0 & 0 & 0 & 0 \\ U_{21} & U_{22} & 0 & 0 & 0 & 0 & 0 & 0 \\ 0 & 0 & U_{33} & U_{34} & 0 & 0 & 0 & 0 \\ 0 & 0 & U_{43} & U_{44} & 0 & 0 & 0 & 0 \\ 0 & 0 & 0 & 0 & U_{55} & U_{56} & 0 & 0 \\ 0 & 0 & 0 & 0 & U_{65} & U_{66} & 0 & 0 \\ 0 & 0 & 0 & 0 & 0 & 0 & U_{77} & U_{78} \\ 0 & 0 & 0 & 0 & 0 & 0 & U_{87} & U_{88} \end{pmatrix}$$

 ∞^{n^2} ∞^{2n}

r = number of reversible circuits
 = number of $n \times n$ permutation matrices

u = number of quantum circuits
 = number of $n \times n$ unitary matrices

w	$n = 2^w$	$r = n!$	$u = \infty^{n^2}$
1	2	2	∞^4
2	4	24	∞^{16}
3	8	40,320	∞^{64}
4	16	20,922,789,888,000	∞^{256}

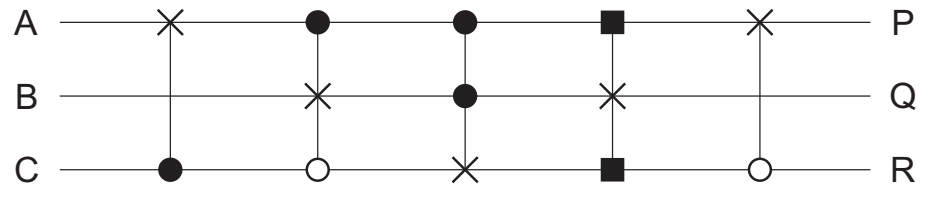

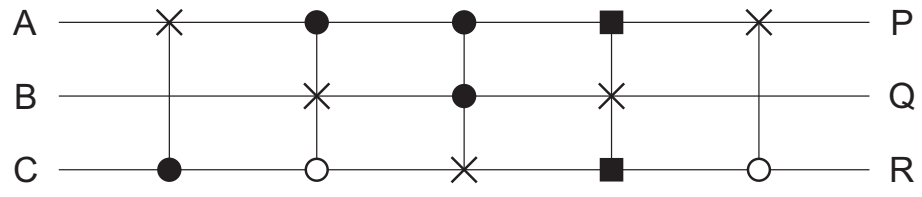

$$\infty^{2^{w+1}}$$

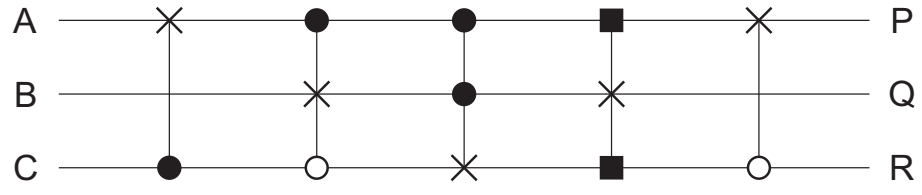

$$\infty^{2^{w+1}} \times \infty^{2^{w+1}}$$

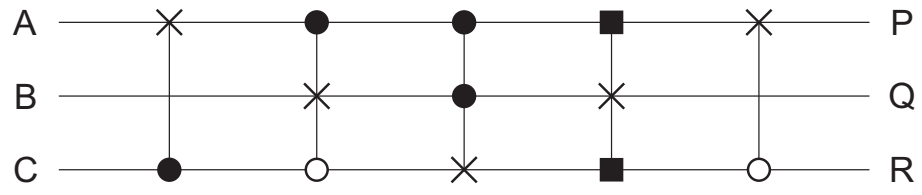

$$\infty^{2^{w+1}} \times \infty^{2^{w+1}} \times \dots \times \infty^{2^{w+1}}$$

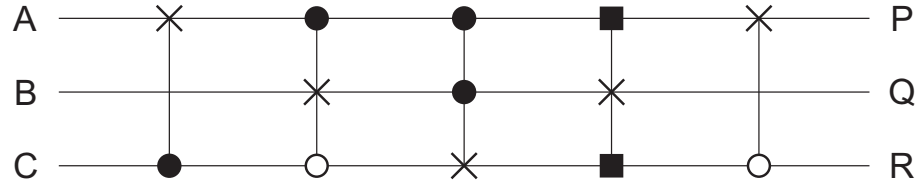

$$\infty^{2^{w+1}} \times \infty^{2^{w+1}} \times \dots \times \infty^{2^{w+1}}$$

$$= \left(\infty^{2^{w+1}} \right)^{2^{w-1}} = \infty^{2(2^{w-1})2^w}$$

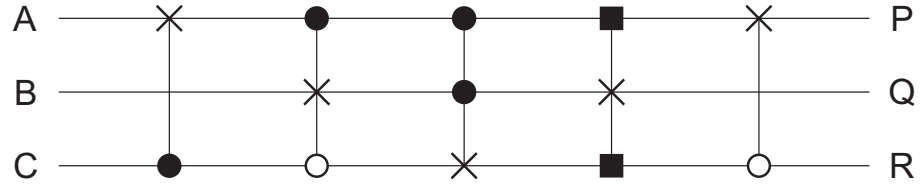

$$\infty^{2^{w+1}} \times \infty^{2^{w+1}} \times \dots \times \infty^{2^{w+1}}$$

$$= \left(\infty^{2^{w+1}} \right)^{2^{w-1}} = \infty^{2(2^{w-1})2^w}$$

$$< \infty^{(2^w)^2} = \infty^{2^{2w}}$$

